

# STEERING WHEEL INSTALLATION INSTRUCTION SUPPLEMENT

For all cars having a part  
that looks like this

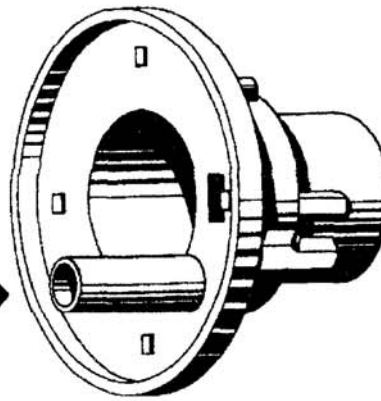

After removal of your old steering wheel, it will be necessary to remove the horn contact plunger and its spring from the plastic horn contact assembly, which should still be on your steering shaft. This horn contact plunger and spring will be replaced in the following manner:

In your kit, you will find a horn contact assembly consisting of two plastic parts, a long spring, brass plunger and a wire lead.

Separate these parts and you will use only the following in your installation:

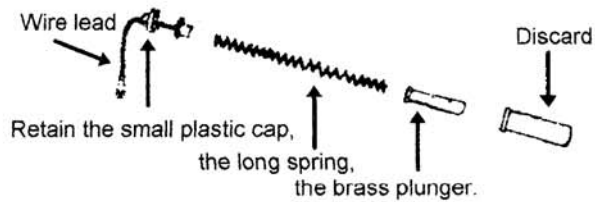
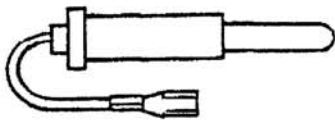

After you have secured the hub to the steering shaft and before final installation of post cover and steering wheel, you should insert the spring through the hub into your plastic horn contact assembly.

The brass plunger and cap should be placed over the spring and held in place with scotch tape so that you can complete your assembly in the usual manner.

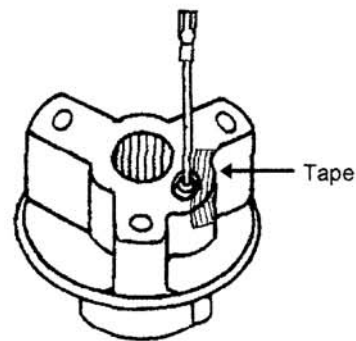
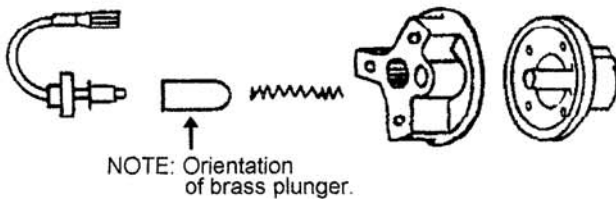

## Our Limited Warranty

We warrant this product for ninety (90) days from the date of original purchase to be free from defects in materials and workmanship. If, during this period, the product fails under normal usage because of a manufacturing defect, then we will replace or repair the item. To obtain repair or replacement under the terms of this warranty, notify us at 700 Allen Avenue, Glendale, California 91201. Proof of purchase and date of purchase are required to validate warranty.

All implied warranties, including warranty of merchantability, are limited to this same ninety-day period from date of original purchase. We are not liable for any direct or consequential loss or property damage arising from any use of this product. This warranty gives you specific legal rights and you may also have other rights that vary from state to state. Offer good in U.S.A. and Canada only.

### IMPORTANT

FOR YOUR OWN SAFETY, DO NOT USE THIS WHEEL FOR ANY COMPETITIVE OR COMMERCIAL RACING PURPOSES. RACING DOES NOT CONSTITUTE NORMAL USAGE AND THEREFORE MAKES THIS WARRANTY VOID.