

CLUTCH

ABC123

Entire Article
2000 Chevrolet Camaro

ARTICLE BEGINNING

2000-01 CLUTCHES
General Motors

Chevrolet; Camaro
Pontiac; Firebird

APPLICATION

MANUAL TRANSMISSION APPLICATIONS

AA
Application Transmision Model (RPO Code)

Chevrolet Camaro

- 3.8L Borg-Warner T5 5-Speed (M49)
- 5.7L Borg-Warner T56 6-Speed (MM6)

Pontiac Firebird

- 3.8L Borg-Warner T5 5-Speed (M49)
- 5.7L Borg-Warner T56 6-Speed (MM6)

AA

DESCRIPTION & OPERATION

System uses a single-plate clutch disc, a diaphragm spring pressure plate and a permanently lubricated clutch release bearing. Clutch release system is hydraulic. System consists of a clutch pedal, clutch master cylinder, clutch actuator cylinder, clutch release fork and concentric actuator/release bearing combination located in the clutch housing. The hydraulic system provides automatic clutch release adjustment.

BLEEDING

CAUTION: Do not use silicone, mineral or paraffin base oil in clutch hydraulic system, or damage to rubber parts in cylinders may occur.

NOTE: Bleeding is necessary if system has been opened or if air has been drawn into system due to low fluid level in reservoir.

Ensure reservoir is filled with NEW clutch hydraulic fluid. Raise and support vehicle. Attach hose to clutch actuator bleeder, located on left side of transmission. Submerge other end of hose in container of clutch hydraulic fluid. Depress clutch pedal slowly and hold. Loosen bleeder to purge air from system. Tighten bleeder. Repeat bleeding procedure until air is completely purged and no bubbles are visible. Fill reservoir.

ADJUSTMENTS

CLUTCH PEDAL FREE PLAY & PEDAL HEIGHT

CLUTCH

ABC123

Entire Article
2000 Chevrolet Camaro

Clutch pedal free play and pedal height are automatically adjusted. No manual adjustment is required.

CLUTCH PRESSURE PLATE

NOTE: Pressure plate adjustment is only required when clutch disc is worn and pressure plate has compensated for wear.

1) Place pressure plate (flat surface down) on press. Compress pressure plate diaphragm spring fingers until tension is released from stepped adjusting ring. Place 2 screwdrivers against 2 of 3 stepped adjusting tension spring stops, just ahead of adjusting ring tension springs.

2) Using screwdrivers, rotate stepped adjusting ring counterclockwise (compressing tension springs) until adjusting ring steps are fully adjusted outward, and then continue to hold in position. Release pressure from pressure plate diaphragm spring fingers. Release adjusting ring tension spring stops. Remove pressure plate from press.

TROUBLE SHOOTING

NOTE: For trouble shooting, see appropriate table in TROUBLE SHOOTING article in GENERAL INFORMATION.

REMOVAL & INSTALLATION

WARNING: Deactivate air bag system before performing any service operation. See appropriate AIR BAG RESTRAINT SYSTEMS article in ACCESSORIES & EQUIPMENT. Do not apply electrical power to any component on steering column without first deactivating air bag system. Air bag may deploy.

CAUTION: When battery is disconnected, vehicle computer and memory systems may lose memory data. Driveability problems may exist until computer systems have completed a relearn cycle. See COMPUTER RELEARN PROCEDURES article in GENERAL INFORMATION before disconnecting battery.

CLUTCH ASSEMBLY

CAUTION: Disconnect clutch master cylinder push rod from pedal before performing any service requiring actuator cylinder removal. If clutch pedal is depressed with actuator cylinder removed and wired aside, permanent actuator cylinder damage will result.

Removal (5-Speed Transmission)

1) Disconnect negative battery cable. Set parking brake. Place shift lever in Neutral. Unscrew shift control knob from shift lever. Unsnap floor console accessory bin, if required. Open console armrest door. Remove coin holder from inside console. Unsnap switch

CLUTCH

ABC123

Entire Article
2000 Chevrolet Camaro

plate from floor console. Disconnect electrical connectors from switches in console, if equipped.

2) Remove console trim plate bolts, and lift up trim plate. Disconnect ashtray light connector. Disconnect cigarette lighter electrical connector. Remove console trim plate. Remove console-to-floor bolts. Raise parking brake handle as far as possible.

3) If parking brake cannot be pulled up far enough to remove console, release parking brake. Hold adjuster pawl disengaged, and pull parking brake handle up as far as possible. Disconnect power outlet electrical connector. Remove console from vehicle. Raise and support vehicle. Drain transmission fluid.

4) Mark drive shaft in relation to pinion gear yoke for installation reference. Remove center support bolts/screws. Remove center support bearing and washers from torque arm. Remove drive shaft bolts/screws and retainers. Support drive shaft during removal. Withdraw slip yoke from transmission. Move shaft rearward, under differential housing, and remove from vehicle. Tape bearing caps if loose.

5) Support rear axle with jack stands. Remove rear axle torque arm bolts at rear axle. Remove torque arm inner and outer brackets. Remove torque arm. Remove exhaust pipe bolts at exhaust manifolds. Disconnect electrical connector from oxygen sensor, and remove oxygen sensor. Loosen muffler clamp bolt, and separate catalytic converter from muffler pipe. Remove converter hanger bolts and hanger.

6) Disconnect electrical connectors from vehicle speed sensor and back-up light on left side of transmission. Remove wiring harness clip bolts on both sides of transmission. Remove starter. Remove left and right transmission braces. Remove flywheel housing cover bolts, and remove cover. Using Quick Disconnect Tool (J-36221), depress White circular release ring on actuator hose while pulling lightly on master cylinder hose. Disconnect clutch actuator cylinder hose from clutch master cylinder hose. Protect both hose coupling ends from dirt and damage.

7) Support engine with a safety stand. Install transmission support to transmission jack, and attach assembly to transmission. Remove transmission support bolts and support. Remove transmission mount bolts and mount. Remove flywheel housing bolts and nuts from engine. Slowly lower transmission from vehicle. Remove transmission vent tube.

8) Remove bleed screw, hydraulic line and retaining bolts from clutch actuator, and remove actuator. Remove bolts holding clutch housing to transmission, and separate transmission from clutch housing. Mark pressure plate in relation to flywheel for installation reference, and remove pressure plate bolts. Remove clutch disc and pressure plate assembly from engine. See Fig. 1.

CLUTCH

ABC123

Entire Article
2000 Chevrolet Camaro

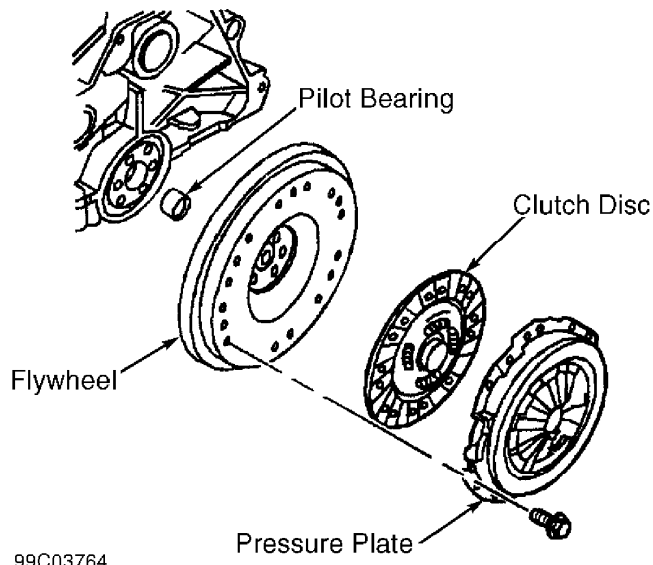

Fig. 1: Exploded View Of Clutch Assembly
Courtesy of General Motors Corp.

CAUTION: Replace flywheel, pressure plate and clutch disc as a set if clutch disc requires replacement.

Inspection

1) Clean oil, grease, metal deposits, etc. from flywheel mating surfaces. If flywheel or pressure plate runout is greater than .050" (1.27 mm), flywheel, pressure plate and clutch disc must be replaced as a set. Inspect flywheel for cracks, heat marks, warpage or other damage. Slight surface scoring can be removed with sandpaper. Replace or resurface as necessary.

2) Check pressure plate for warpage, heat marks (Blue coloring) and cracks. Check diaphragm spring fingers for uneven height and wear at release bearing contact area. Replace pressure plate if excessively worn or damaged. Replace clutch disc if runout is greater than .020" (.51 mm). Check pilot bearing rotation. If roughness is felt or bearing does not spin freely, replace bearing.

Installation

1) Position clutch disc with damper springs toward transmission, and stamped letters "FLYWHEEL SIDE" toward flywheel. Use Clutch Arbor (J-33169) to support and center clutch disc.

2) Position pressure plate onto flywheel. Match Gray paint spot on pressure plate with "X" marked on flywheel. Using a crisscross sequence, tighten pressure plate bolts gradually and evenly to prevent distortion. To complete installation, reverse removal procedure. Use NEW flywheel-to-crankshaft bolts. Tighten bolts and nuts to specification. See TORQUE SPECIFICATIONS.

Removal (6-Speed Transmission)

1) Disconnect negative battery cable. Set parking brake. Place shift lever in Neutral. Unscrew shift control knob from shift lever. Unsnap floor console accessory bin, if required. Open console armrest door. Remove coin holder from inside console. Unsnap switch

CLUTCH

ABC123

Entire Article
2000 Chevrolet Camaro

plate from floor console. Disconnect electrical connectors from switches in console, if equipped.

2) Remove console trim plate bolts, and lift up trim plate. Disconnect ashtray light connector. Disconnect cigarette lighter electrical connector. Remove console trim plate. Remove console-to-floor bolts. Raise parking brake handle as far as possible. If parking brake cannot be pulled up far enough to remove console, release parking brake. Hold adjuster pawl disengaged, and pull parking brake handle up as far as possible.

3) Disconnect power outlet electrical connector. Remove console from vehicle. Remove shift lever bolts and remove shift lever. Remove shift control closeout boot bolts. Remove closeout boot. Remove shift control bolts and remove control assembly. Clean sealant from housing and shift control assembly. Raise and support vehicle. Drain transmission fluid.

4) Support rear axle with jack stands. Mark drive shaft in relation to pinion gear yoke for installation reference. Remove drive shaft bolts/screws and retainers. Support drive shaft during removal. Withdraw slip yoke from transmission. Move shaft rearward, under differential housing, and remove from vehicle. Tape bearing caps if loose.

5) Remove rear axle torque arm bolts at rear axle. Remove torque arm inner and outer brackets. Remove torque arm. Disconnect electrical connector from right-side heated oxygen sensor, and remove oxygen sensor. Disconnect rear heated oxygen sensor clip from transmission brace. Disconnect rear heated oxygen sensor electrical connector, and remove sensor from behind right-side converter.

6) Remove exhaust manifold-to-exhaust pipe bolts. Remove nuts attaching right-side converter to left-side converter. Remove converter hanger bolts, and remove hanger from hanger bracket. Loosen muffler clamp bolt, and separate catalytic converter from muffler pipe. Remove converter by sliding out of exhaust pipe. Disconnect electrical connectors from transmission oil level sensor. Remove left-side converter in same manner as right-side converter.

7) Remove starter. Remove wiring harness clip bolts. Disconnect electrical connector from back-up light switch, skip shift solenoid, reverse lock-out solenoid, vehicle speed sensor and oxygen sensors. Remove wiring harness bracket retainer and bracket. Support engine with jack stands.

8) Using Quick Disconnect Tool (J-36221), depress white circular release ring on actuator hose while pulling lightly on master cylinder hose. Disconnect clutch actuator cylinder hose from clutch master cylinder hose. Protect both hose coupling ends from dirt and damage. Install transmission support to transmission jack, and attach assembly to transmission. Remove transmission support bolts and support. Remove transmission mount bolts and mount.

9) Slowly lower transmission to access flywheel housing bolts. Remove flywheel housing-to-engine bolts. Remove transmission from vehicle. Remove transmission vent tube. Remove clutch actuator cylinder bolts, and remove actuator. Remove bolts holding clutch housing to transmission, and separate transmission from clutch housing. Mark pressure plate in relation to flywheel for installation reference and remove pressure plate bolts. Remove clutch disc and pressure plate assembly from engine.

CLUTCH

ABC123

Entire Article
2000 Chevrolet Camaro

CAUTION: Replace flywheel, pressure plate and clutch disc as a set if clutch disc requires replacement.

Inspection

1) Clean oil, grease, metal deposits, etc. from flywheel mating surfaces. If flywheel or pressure plate runout is greater than .050" (1.27 mm), flywheel, pressure plate and clutch disc must be replaced as a set. Inspect flywheel for cracks, heat marks, warpage or other damage. Slight surface scoring can be removed with sandpaper. Replace or resurface as necessary.

2) Check pressure plate for warpage, heat marks (Blue coloring) and cracks. Check diaphragm spring fingers for uneven height and wear at release bearing contact area. Replace pressure plate if excessively worn or damaged. Replace clutch disc if runout is greater than .020" (.51 mm). Check pilot bearing rotation. If roughness is felt or bearing does not spin freely, replace bearing.

3) If replacing flywheel, check old flywheel for balance weights inserted in weight holes. If weights are installed on old flywheel, new balance weights **MUST** be installed on new flywheel in same hole locations as on old flywheel.

Installation

1) Install flywheel if removed. Apply Thread Lock (PN 12345382) to flywheel bolts and loosely install bolts. Tighten bolts in sequence to specification. See Figs. 2 and TORQUE SPECIFICATIONS. Position clutch disc with damper springs toward transmission, and stamped letters FLYWHEEL SIDE toward flywheel. Use Clutch Arbor (J-38836) to support and center clutch disc.

2) Position pressure plate onto flywheel. Align match marks made during removal. Using a crisscross sequence, tighten pressure plate bolts gradually and evenly to prevent distortion. See Fig. 2. To complete installation, reverse removal procedure. Tighten all bolts and nuts to specification. See TORQUE SPECIFICATIONS.

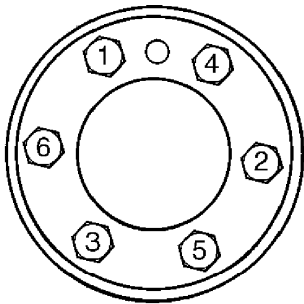

97A03598

Fig. 2: Flywheel Tightening Sequence - 5.7L (Pressure Plate Sequence Is Same)

Courtesy of General Motors Corp.

CLUTCH ACTUATOR

Removal

Disconnect negative battery cable. Remove transmission. See CLUTCH ASSEMBLY. Remove bleeder screw from actuator. Using a small

CLUTCH

ABC123

Entire Article
2000 Chevrolet Camaro

drift, remove roll pin retaining fluid fitting to actuator. Remove actuator attaching bolts, and remove actuator.

NOTE: When reconnecting quick-connect hydraulic hose fittings, pull back on fittings to verify engagement. DO NOT rely on audible click or visual verification. Also, check clutch hydraulic hoses for twists or kinks.

Installation

Reverse removal procedure. Tighten bolts and nuts to specification. See TORQUE SPECIFICATIONS. Bleed clutch hydraulic system. See BLEEDING.

CLUTCH MASTER CYLINDER

Removal

1) Disconnect negative battery cable. Remove driver side instrument panel insulator. Remove driver knee bolster under instrument panel. Remove clutch pedal retaining pin. Disconnect clutch master cylinder push rod from clutch pedal. Remove master cylinder attaching nuts and "U" bolt. With hydraulic line attached, remove clutch master cylinder from front of dash.

2) Raise and support vehicle. Using Quick Disconnect (J-36221), depress white circular release ring on actuator hose while pulling lightly on master cylinder hose. Disconnect clutch actuator cylinder hose from clutch master cylinder hose. Protect both hose coupling ends from dirt and damage. Lower vehicle.

3) Remove master cylinder reservoir push-in retainer. Slide reservoir out from hood strut bracket. Remove master cylinder and reservoir.

NOTE: When reconnecting quick-connect hydraulic hose fittings, pull back on fittings to verify engagement. DO NOT rely on audible click or visual verification. Also, check clutch hydraulic hoses for twists or kinks.

Installation

Install clutch master cylinder and reservoir. Lubricate push rod bushing on clutch pedal. To complete installation, reverse removal procedure. Tighten bolts and nuts to specification. See TORQUE SPECIFICATIONS. Bleed clutch hydraulic system. See BLEEDING.

CLUTCH PEDAL ANTICIPATE SWITCH

Removal

Disconnect negative battery cable. Remove driver side knee bolster. Disconnect clutch anticipate switch electrical connector, and remove switch from bracket.

Installation

Install switch into pedal bracket until fully seated. Push clutch pedal all the way down. Push switch through its retainer until switch barrel is touching pedal target, and switch plunger is fully

CLUTCH

ABC123

Entire Article
2000 Chevrolet Camaro

depressed. Connect electrical connector. Install knee bolster.
Reconnect negative battery cable.

CLUTCH PEDAL POSITION SWITCH

Removal & Installation

Disconnect negative battery cable. Remove driver side knee bolster. Remove clutch pedal position switch electrical connector. Lift switch slightly then pull to remove. To install, reverse removal procedure. Insert switch locators into top of slots, and then slide down to lock.

CLUTCH RELEASE BEARING

Removal & Installation

Remove driveline support assembly and transmission. See CLUTCH ASSEMBLY. Remove release bearing. Rotate bearing in either direction. Compression spring load will push bearing off end of actuator cylinder. To install, reverse removal procedure. Bearing will snap over retainer tab and will be self-retained on actuator cylinder.

PILOT BEARING

NOTE: Do not use grease under pressure to force pilot bearing from crankshaft, or damage may result.

Removal & Installation

Remove driveline support assembly and transmission. See CLUTCH ASSEMBLY. Remove pressure plate, clutch plate and flywheel. Using Pilot Bearing Remover (J-43276), remove clutch pilot bearing. Using Pilot Bearing Installer (J-38836), install clutch pilot bearing. To install, reverse removal procedure. Tighten all bolts and nuts to specification. See TORQUE SPECIFICATIONS.

OVERHAUL

NOTE: Manufacturer recommends replacement of faulty clutch actuator and master cylinders, and does not provide overhaul procedures.

TORQUE SPECIFICATIONS

TORQUE SPECIFICATIONS

AA	
Application	Ft. Lbs. (N.m)
Actuator Bleed Screw	15 (20)
Clutch Housing-To-Engine Bolt	
3.8L (5-Speed)	55 (75)
5.7L (6-Speed)	37 (50)
Drive Shaft Screw	16 (22)
Drive Shaft-To-Center Support Bearing Bolt	37 (50)
Flywheel -To-Crankshaft Bolt	

CLUTCH

ABC123

Entire Article
2000 Chevrolet Camaro

3. 8L (5-Speed) (1)	(2)	11	(15)
5. 7L (6-Speed) (3)			
Step 1		15	(20)
Step 2		37	(50)
Step 3		74	(100)
Master Cylinder Bolt/Nut		15	(20)
Pressure Plate-To-Flywheel Bolt			
3. 8L (5-Speed)	(4)	15	(20)
5. 7L (6-Speed)		52	(70)
Transmission Brace-To-Engine Bolt		21	(28)
Transmission Brace-To-Transmission Bolt		37	(50)
Transmission Mount Bolt			
3. 8L (5-Speed)		36	(48)
5. 7L (6-Speed)		38	(52)
Transmission Mount Nut			
3. 8L (5-Speed)		43	(58)
5. 7L (6-Speed)		77	(104)
Transmission Support Bolt		43	(58)
Transmission-To-Clutch Housing Bolt			
3. 8L (5-Speed)		55	(75)
5. 7L (6-Speed)		37	(50)

INCH Lbs. (N. m)

Actuator Cylinder Bolt	71	(8)
Flywheel Housing Cover Bolt	80	(9)

- (1) - Always use NEW bolts.
- (2) - Rotate bolts an additional 50 degrees.
- (3) - Apply Threadlock (12345382) to all bolts.
- (4) - Rotate bolts an additional 45 degrees.

AA

A00094694

END OF ARTICLE